

SINGLE PORTED TOP SIDE TENSIONER HYDRAULIC HARNESS ASSEMBLY INSTRUCTIONS

(DEAD ENDED & LOOPED)

W-ENG-5525-060

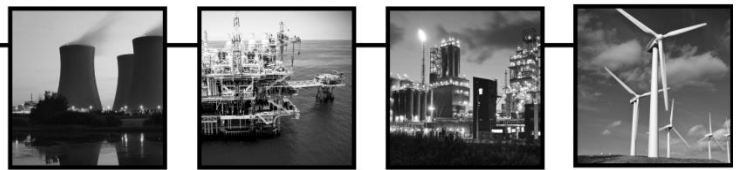

Operating and Maintenance Instructions Original Instructions

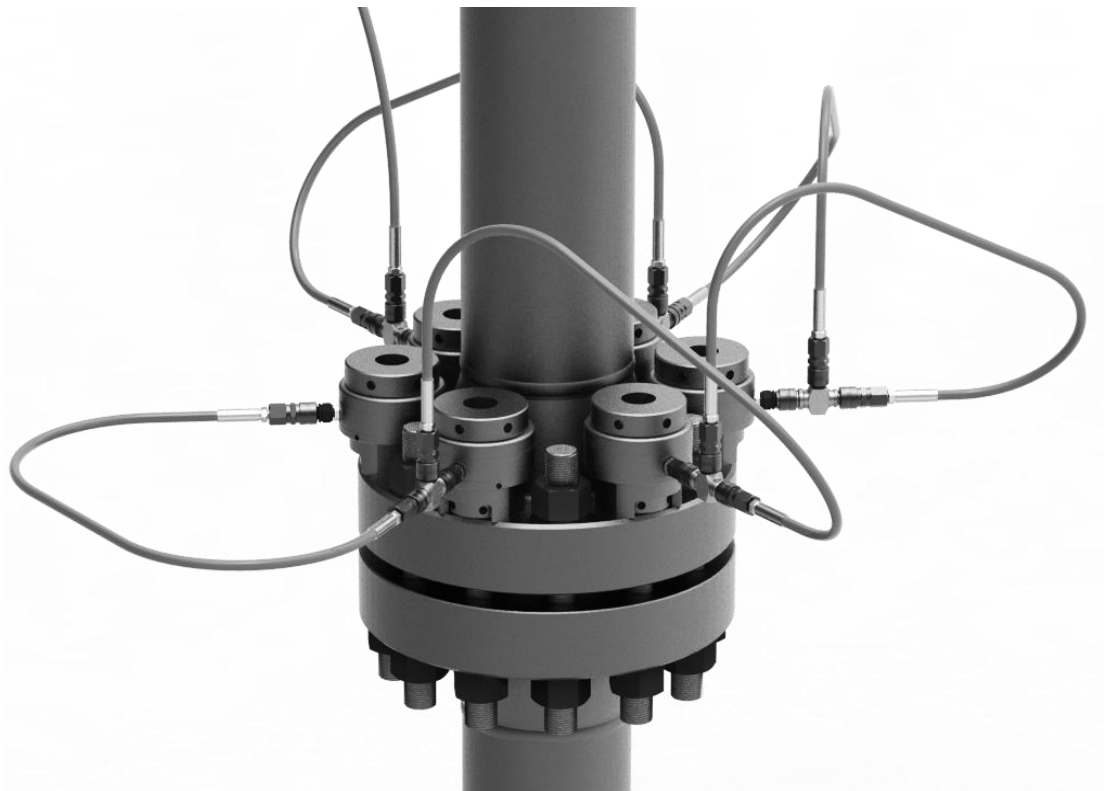

INDEX

1. SAFETY NOTES 3

2. DESCRIPTION OF EQUIPMENT..... 6

2.1. GENERAL..... 6

3. OPERATION 7

3.1. HYDRAULIC FITTINGS 7

3.2. CONNECTION OF A DEAD ENDED HYDRAULIC HARNESS 8

3.3. CONNECTION OF A LOOPED HYDRAULIC HARNESS..... 10

4. TROUBLE SHOOTING GUIDE 13

5. STORAGE OF EQUIPMENT 14

5.1. HARNESS AND FITTINGS 14

5.2. AIR DRIVEN PUMP UNIT 14

6. GENERAL ARRANGEMENT DRAWINGS..... 15

7. REVISION HISTORY 19

ANNEX 1. ENVIRONMENTAL STATEMENT..... 20

1. SAFETY NOTES



READ THE OPERATING INSTRUCTIONS



CAUTION: Keep away from oil leakages at high pressure. Fluid escaping from highly pressurised equipment can penetrate the skin, which can cause blood poisoning. In the event of such an accident immediate medical attention should be sought.



In the event of accident or breakdown:
Stop pump, disconnect equipment and turn off air supply.



Wear safety glasses to protect against flying particles



Wear safety shoes at all times



Wear ear protection during operation. Prolonged exposure to high intensity noise may cause loss of hearing



Wear safety gloves



Wear protective clothing

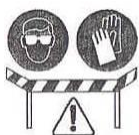

Eye protection must be used.
Wear gloves at all times
Rope off working area and place warning signs.

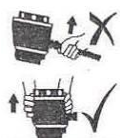

Do not pick up tools by hydraulic hose.
Observe correct lifting procedure at all times.



Do not tamper with hose connections when under pressure

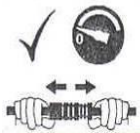

System must be at zero pressure before couplings are disconnected. Check integrity of system before applying any pressure.



Never apply pressure to disconnected fittings. Always check that all connections are good before applying pressure to the system.



Never leave the system unattended when under pressure.



When the system is under pressure DO NOT STAND IN LINE with the direction of force of the tensioners. This is a danger area. Keep this area clear of personnel at all times when the system is under pressure.

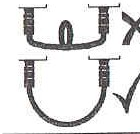

Do not over-bend or kink hoses.



Never pressurise the pump with a disconnected fitting.

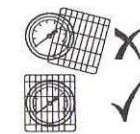

Do not remove gauge covers when fitted.

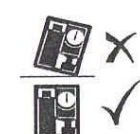

Site pump on a secure, flat, level surface.

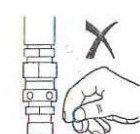

Do not tamper with air pressure relief safety valve on pump.



Check date of calibration certification. If recalibration date has passed, recalibrate gauge.

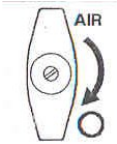

If air supply is interrupted, turn off air stop valve on pump.



24 Hour emergency contact number 44 (0)121 505 0600



Only use genuine Hydratight parts.

2. DESCRIPTION OF EQUIPMENT

2.1. GENERAL

- 2.1.1.** The Hydratight hydraulic harness is designed for use with equipment used in the precision tensioning of bolted joints in an industrial environment. Due to the high degree of competency required to safely operate this type of equipment, it is envisaged that it is to be used by trained professional operators only. The equipment is not intended to be used by untrained operators or in a non-industrial environment.
- 2.1.2.** The tensioning equipment used is application specific, however the harness may be configured to suit different tensioning configurations. It is important to confirm compatibility in terms of hydraulic couplings, operating pressure and any pumps being used before the harness is connected. No attempt should be made to modify any component to fit. If in doubt, contact Hydratight.
- 2.1.3.** This hydraulic harness has been designed to be used in conjunction with a hydraulic pump unit. Hydratight can offer a range of pump options to suit particular applications and thus operators should refer to the specific instructions manual for the pump to be used.

3. OPERATION

3.1. HYDRAULIC FITTINGS

Hydraulic connections are of the following types:

- 3.1.1. Hydraulic tool assembly – care should be taken to ensure that the hydraulic connections on the tools are compatible with the hydraulic connections on the hoses.
- 3.1.2. Hose – the hose end connection is a ¼” BSP fixed male with end cone. A seal is effected by screwing down on to the mating adaptor with sufficient pressure. Any problems are usually minimal and normally solved by applying a slightly higher torque than the minimum required (40-50 Nm or 355-440 lbf.in).

NOTE If the problem persists then the threads should be checked and repaired if possible. If the threads cannot be repaired the component part(s) will need replacing. In the event of any further problems please consult with Hydratight Limited for advice.



**QUICK DISCONNECT
NIPPLE**



TEE FITTING - FEMALE / MALE / MALE



LINK HOSE - COUPLING / COUPLING



FEED HOSE - COUPLING / NIPPLE

3.2. CONNECTION OF A DEAD ENDED HYDRAULIC HARNESS

To connect a dead ended hydraulic harness to the application proceed as follows, refer also to drawings D0604C0000AF, D0304C0000AF, D1203X112XAF & D1304C0000AF as necessary. Pictures enclosed are for guidance only and may not be of the actual hydraulic tools used on the application.

3.2.1. Before connection, ensure that the hydraulic tools are installed correctly on the application to the manufacturer’s specifications.

3.2.2. Connect a tee fitting (female) to the quick disconnect nipple (male) on the first tool and check that the coupling is securely connected to the quick disconnect nipple. Repeat this operation for all of the tools to be pressurised on the application, except for the last tool in the sequence.

NOTE If all the studs and nuts on the application are not being tightened simultaneously then a sensible tightening sequence should be used. If in doubt consult Hydratight Limited for advice.

3.2.3. Connect one end of the feed hose (female) to the tee fitting (male) on the first tool and check that the coupling is securely connected to the quick disconnect nipple.

NOTE At this stage **do not** connect the other end of the feed hose to the pump.

3.2.4. Connect one end of a link hose (female) to the tee fitting (male) on the first tool and check that the coupling is securely connected to the quick disconnect nipple.

First Tool in Sequence

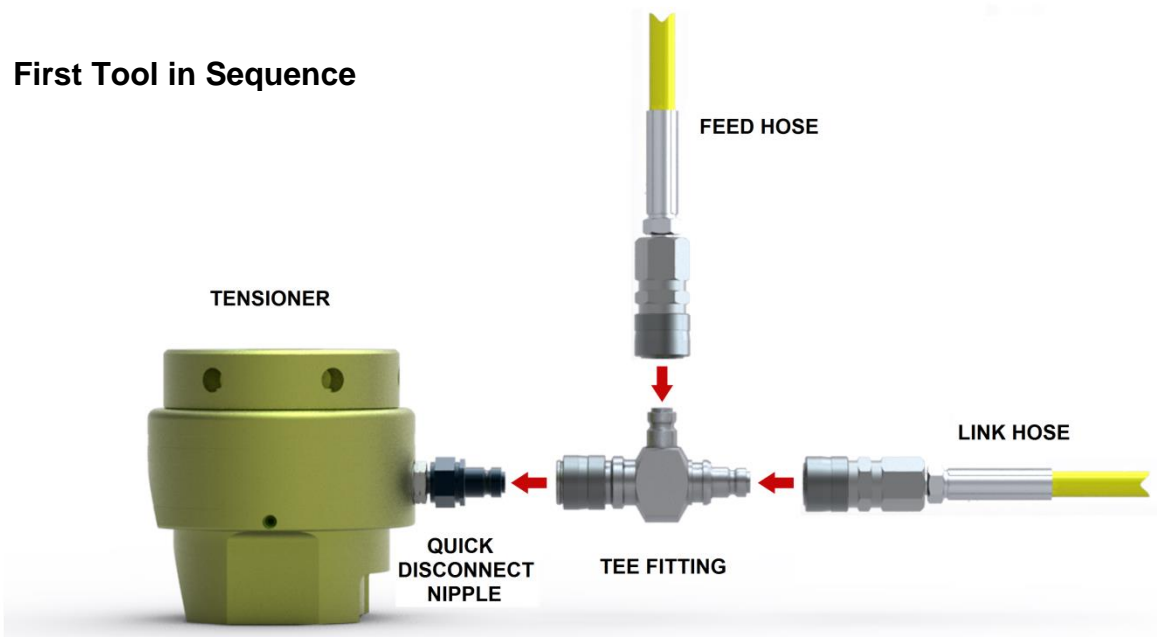

3.2.5. Take the other end of the link hose (female) attached to the tee fitting on the first tool, and connect it to the tee fitting (male) on the second tool and check that the coupling is securely connected to the quick disconnect nipple. Repeat steps 3.2.4 & 3.2.5 until the penultimate tool.

Second Tool in Sequence

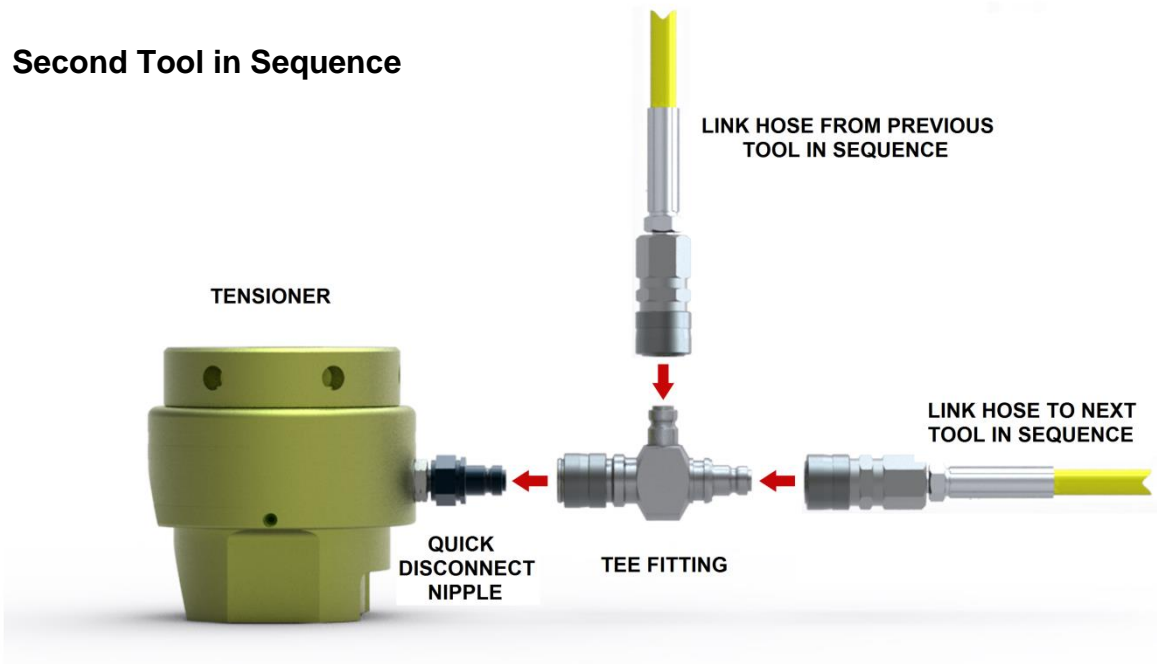

- 3.2.6. Take the disconnected end of the link hose (female) attached to the tee fitting on the penultimate tool in the sequence, and connect it directly to the quick disconnect fitting (male) on the final tool in the sequence and check that the coupling is securely connected to the quick disconnect nipple.

Final Tool in Sequence

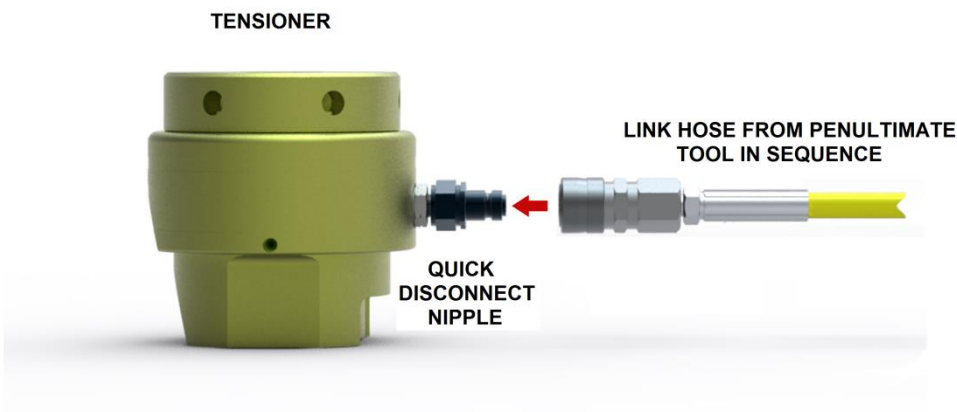

- 3.2.7. Ensuring that all couplings are securely connected, connect the free end of the feed hose to the pump.

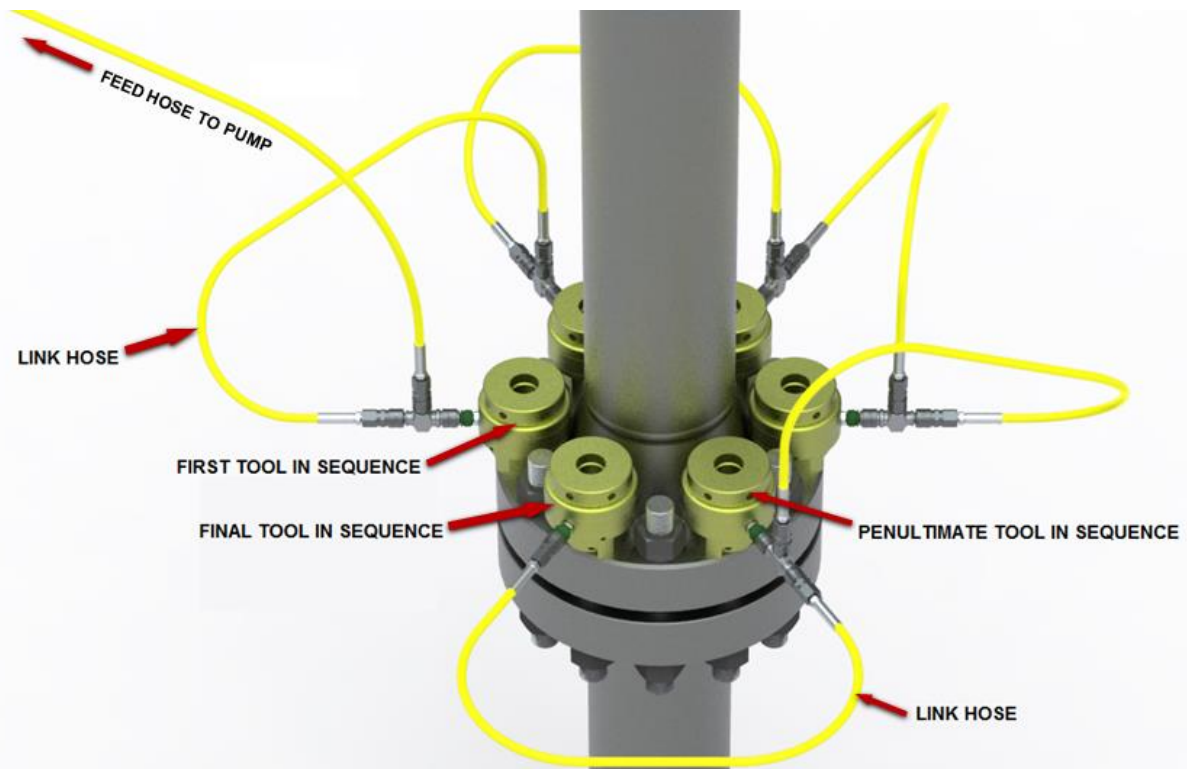

3.2.8. Operate the hydraulic pump to pressurise the hydraulic tool(s), observing to the manufacturer’s specifications until the tightening procedure has been completed.

NOTE Do not exceed the maximum working pressure of the hydraulic tool (refer to technical data sheet).

3.2.9. Release the oil pressure slowly.

3.2.10. Remove the hydraulic harness from the hydraulic tool(s) and fit protective caps to the hydraulic connections.

3.3. CONNECTION OF A LOOPED HYDRAULIC HARNESS

To connect a looped hydraulic harness to the application proceed as follows, refer also to drawings D0604C0000AF, D0304C0000AF, D1203X112XAF & D1304C0000AF as necessary. Pictures enclosed are for guidance only and may not be of the actual hydraulic tools used on the application.

3.3.1. Before connection, ensure that the hydraulic tools are installed correctly on the application to the manufacturer’s specifications.

3.3.2. Connect a tee fitting (female) to the quick disconnect nipple (male) on the first tool and check that the coupling is securely connected to the quick disconnect nipple.

NOTE If all the studs and nuts on the application are not being tightened simultaneously then a sensible tightening sequence should be used. If in doubt consult Hydratight Limited for advice.

3.3.3. Connect a second tee fitting (female) to first tee fitting (male) on the first tool and check that the coupling is securely connected to the quick disconnect nipple.

3.3.4. Connect a tee fitting (female) to the quick disconnect nipple (male) on all of the remaining tools to be pressurised on the application and check that the couplings are securely connected to the quick disconnect nipples.

3.3.5. Connect one end of the feed hose (female) to the second tee fitting (male) on the first tool and check that the coupling is securely connected to the quick disconnect nipple.

NOTE At this stage **do not** connect the other end of the feed hose to the pump.

3.3.6. Connect one end of a link hose (female) to the first tee fitting (male) on the first tool and check that the coupling is securely connected to the quick disconnect nipple.

First Tool in Sequence

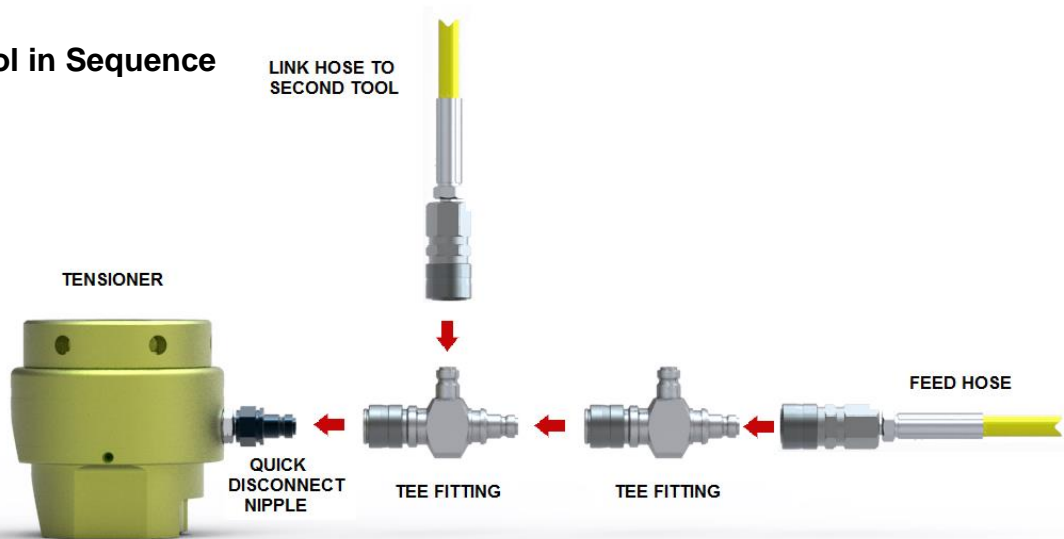

3.3.7. Take the disconnected end of the link hose (female) attached to the tee fitting on the first tool in the sequence, and connect it to the tee fitting (male) on the second tool in the sequence and check that the coupling is securely connected to the quick disconnect nipple. Repeat steps 3.3.4 & 3.3.5 until the penultimate tool.

Second Tool in Sequence

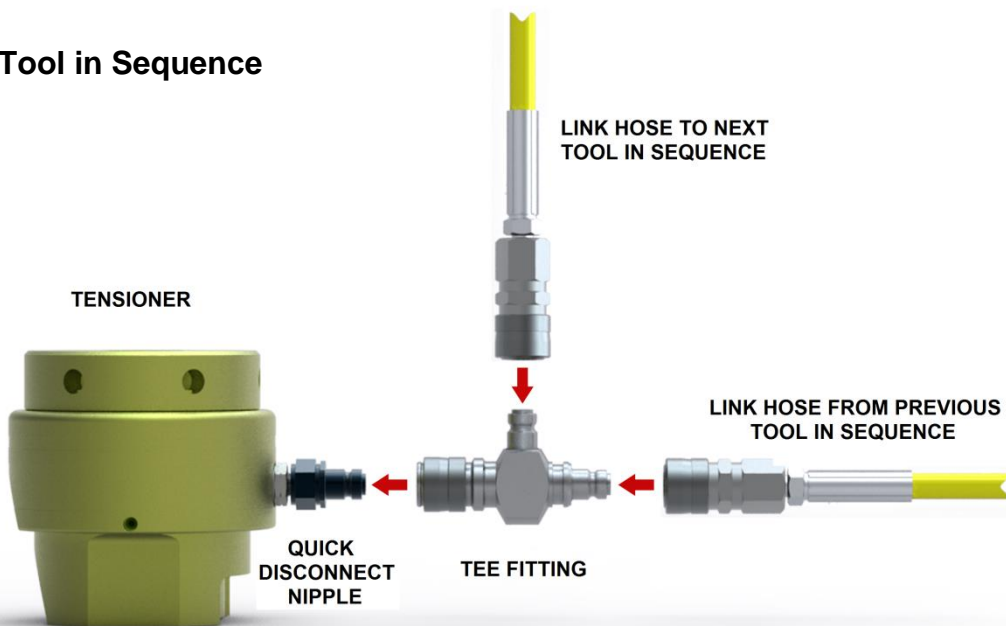

3.3.8. Take the disconnected end of the link hose (female) attached to the tee fitting on the last tool in the sequence, and connect it to the second tee fitting (male) on the first tool in the sequence and check that the coupling is securely connected to the quick disconnect nipple.

Final Connection to the First Tool in Sequence

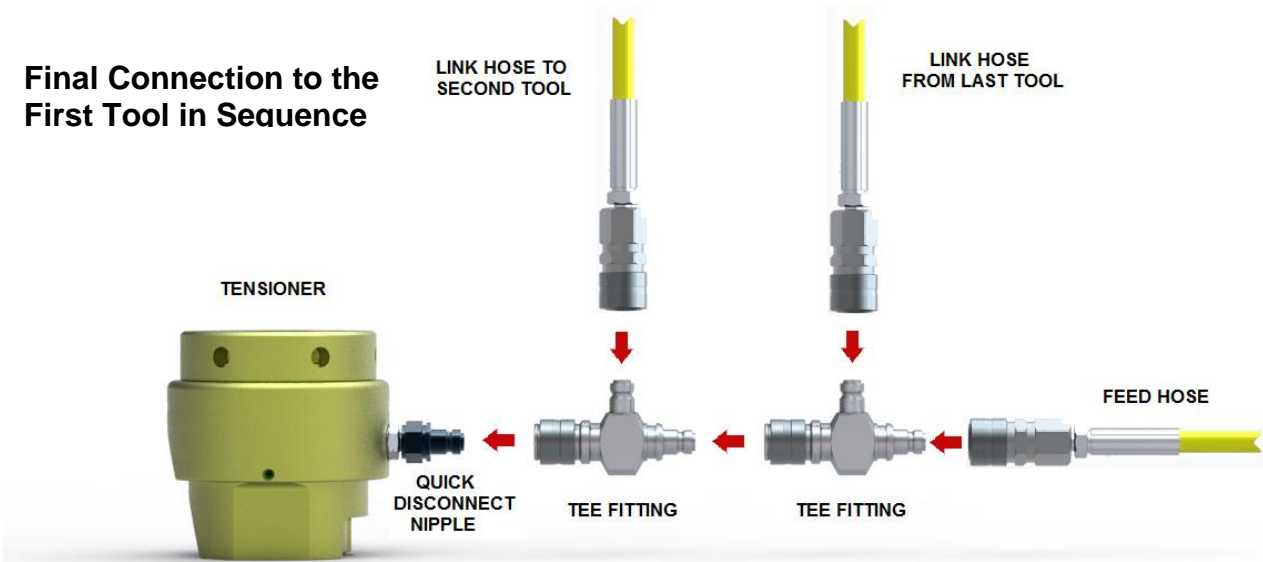

3.3.9. Ensuring that all couplings are securely connected, connect the free end of the feed hose to the pump.

Final Harness Connection Assembly

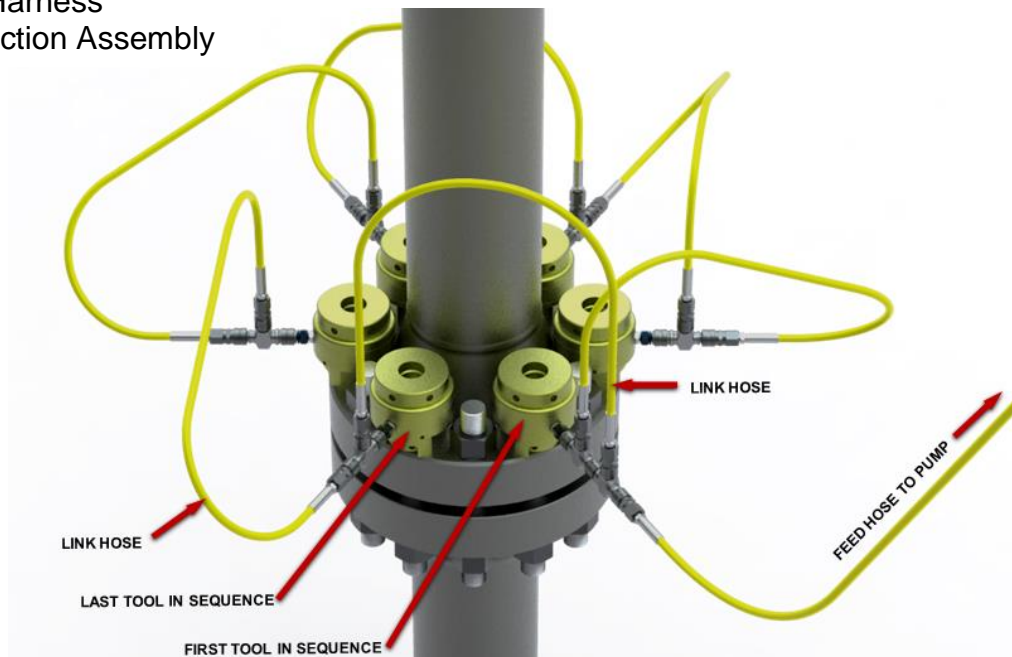

3.3.10. Operate the hydraulic pump to pressurise the hydraulic tool(s), observing to the manufacturer’s specifications until the tightening procedure has been completed.

NOTE Do not exceed the maximum working pressure of the hydraulic tool (refer to technical data sheet).

3.3.11. Release the oil pressure slowly.

3.3.12. Remove the hydraulic harness from the hydraulic tool(s) and fit protective caps to the hydraulic connections.

4. TROUBLE SHOOTING GUIDE

Fault	Possible Cause	Corrective Action
Oil is leaking from a hydraulic connection.	The connection is not seating properly.	Tighten the connection. Where applicable replace connection components (see general arrangement drawing).

5. STORAGE OF EQUIPMENT

5.1. HARNESS AND FITTINGS

- 5.1.1. Wipe all hoses clean and apply a light coating of oil or suitable rust inhibitor to all nipples, couplings, and tee blocks.
- 5.1.2. Always keep dust caps fitted to nipples and couplings when hoses are not in use.

5.2. AIR DRIVEN PUMP UNIT

- 5.2.1. Always store the pump upright.
- 5.2.2. Apply light oil coating or suitable rust inhibitor to all exposed un-plated metal items.
- 5.2.3. Leave the oil Return-To-Tank valve in the open position.
- 5.2.4. Leave the air control valve in the open position.
- 5.2.5. Always keep dust covers on inlet/outlet hydraulic fittings.

6. GENERAL ARRANGEMENT DRAWINGS

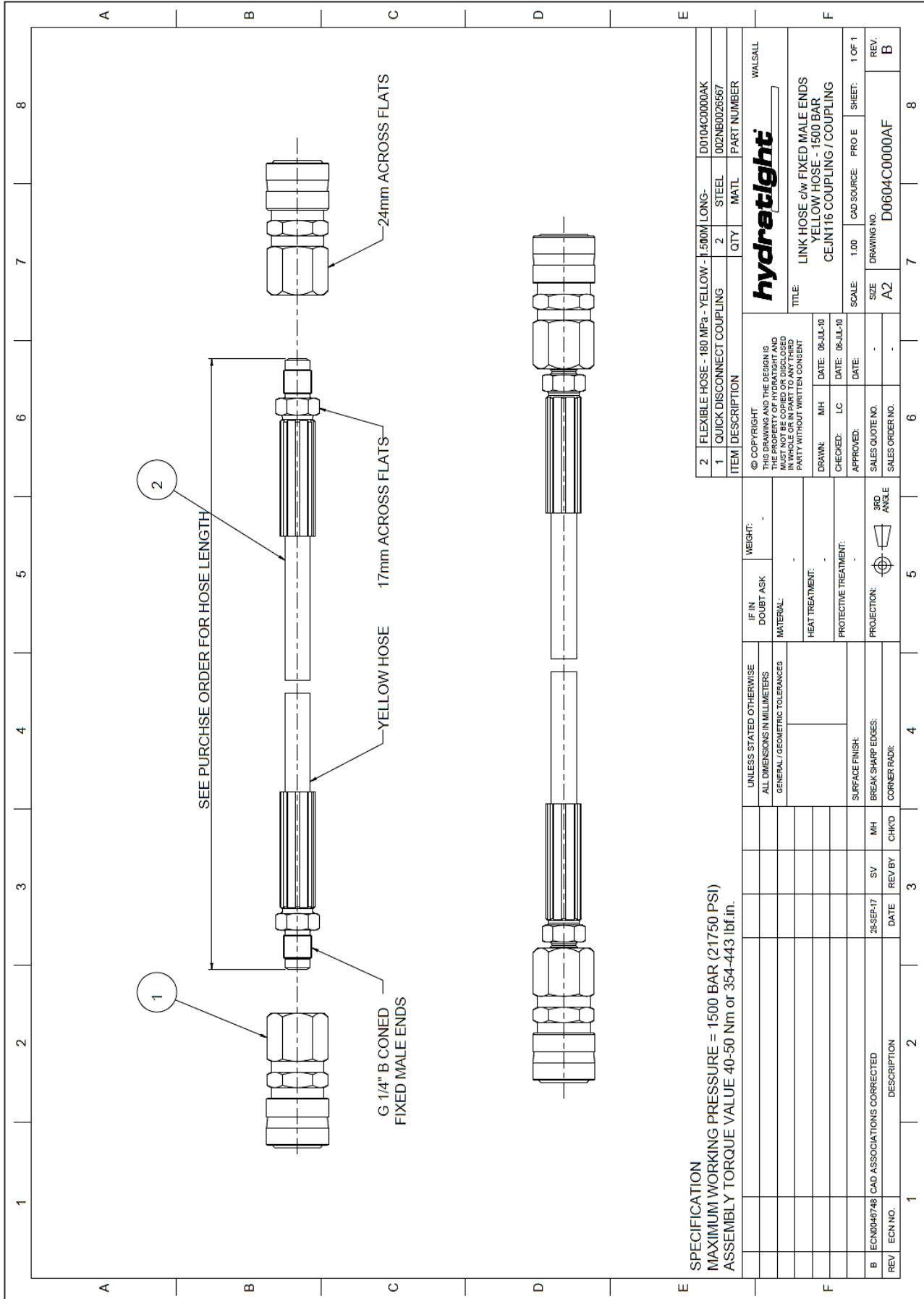

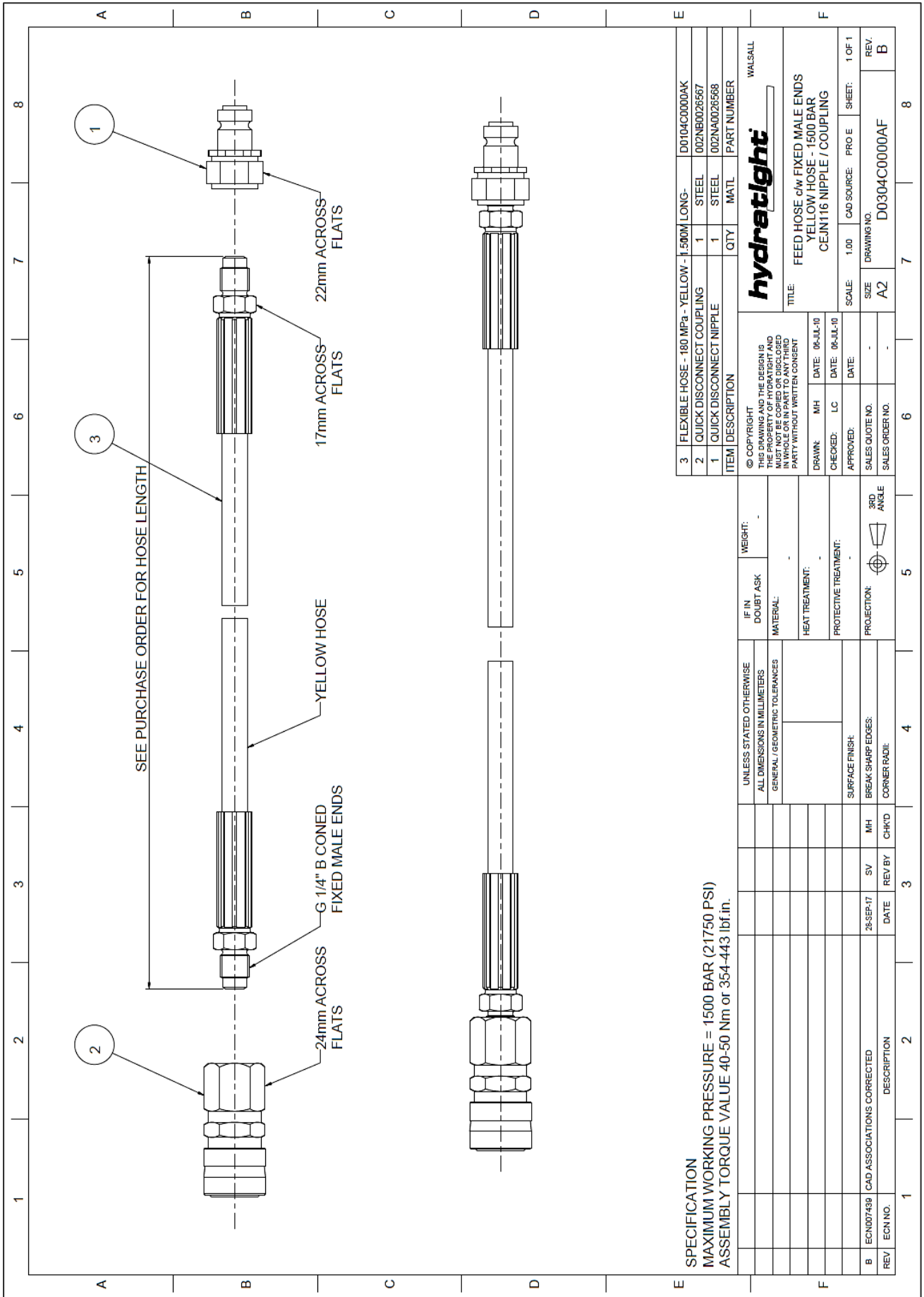

SPECIFICATION
 MAXIMUM WORKING PRESSURE = 1500 BAR (21750 PSI)
 ASSEMBLY TORQUE VALUE 40-50 Nm or 354-443 lbf.in.

ITEM	DESCRIPTION	QTY	MATL	PART NUMBER
3	FLEXIBLE HOSE - 180 MPa - YELLOW - JL500M	1	STEEL	D0104C0000AK
2	QUICK DISCONNECT COUPLING	1	STEEL	002NB0026567
1	QUICK DISCONNECT NIPPLE	1	STEEL	002NA0026568

© COPYRIGHT THIS DRAWING AND THE DESIGN IS THE PROPERTY OF WALSALL AND MUST NOT BE COPIED OR DISCLOSED IN WHOLE OR IN PART TO ANY THIRD PARTY WITHOUT WRITTEN CONSENT		WALSALL hydratight	
DRAWN: MH	DATE: 06-JUL-10	TITLE: FEED HOSE w/ FIXED MALE ENDS	
CHECKED: LC	DATE: 06-JUL-10	YELLOW HOSE - 1500 BAR	
APPROVED: DATE:	DATE:	CEJN116 NIPPLE / COUPLING	
SALES QUOTE NO.:	SCALE: 1:00	CAD SOURCE: PRO E	SHEET: 1 OF 1
SALES ORDER NO.:	SIZE: A2	DRAWING NO.:	REV. B
		D0304C0000AF	

UNLESS STATED OTHERWISE	IF IN DOUBT ASK	WEIGHT:	
ALL DIMENSIONS IN MILLIMETERS	MATERIAL:		
GENERAL / GEOMETRIC TOLERANCES	HEAT TREATMENT:		
	PROTECTIVE TREATMENT:		
	PROJECTION:	3RD ANGLE	
	DATE	DATE	DATE
	SV	MH	
	REV BY	CHK'D	
	DATE		
B	ECH007489	CAD ASSOCIATIONS CORRECTED	
REV	ECN NO.	DESCRIPTION	

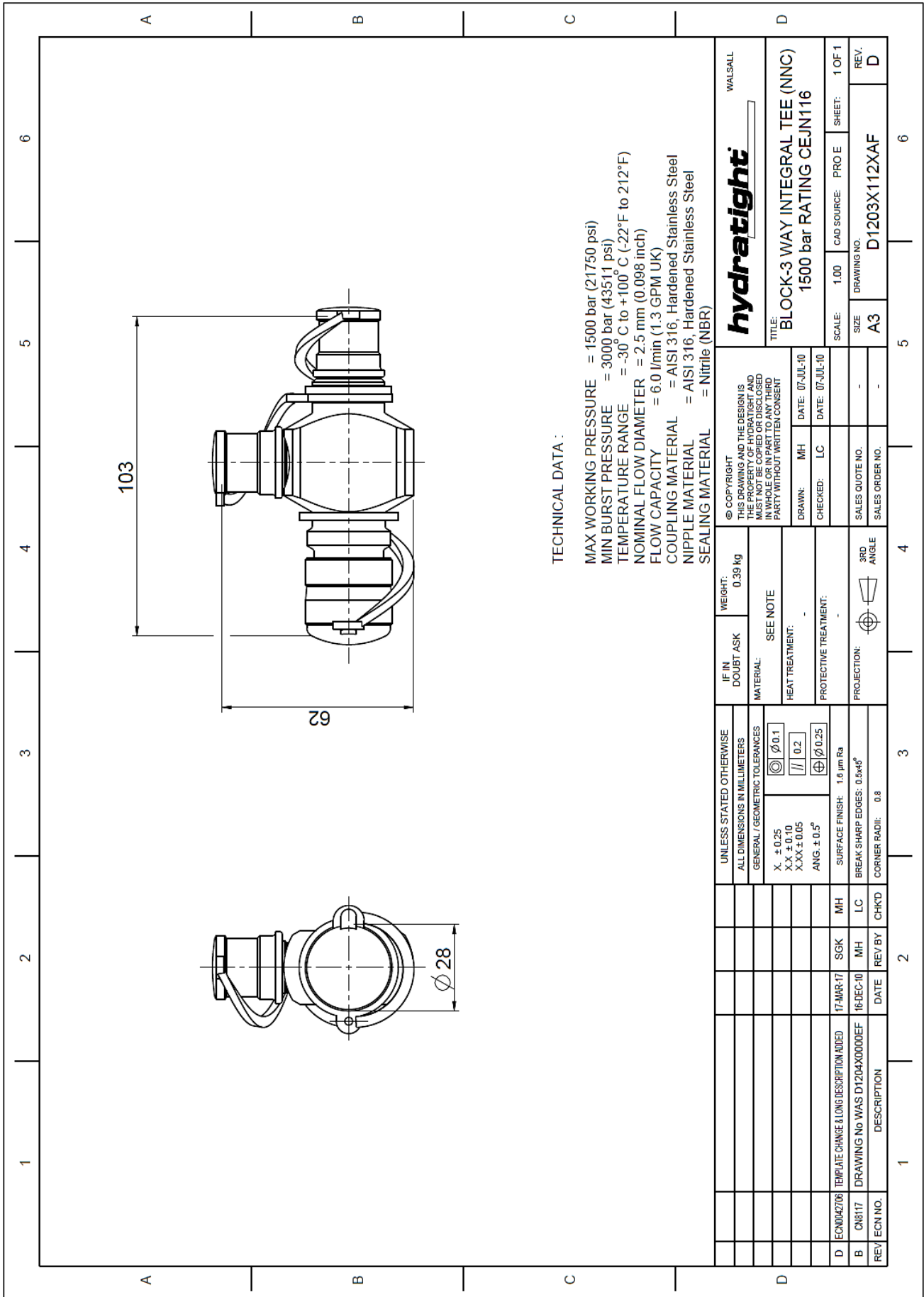

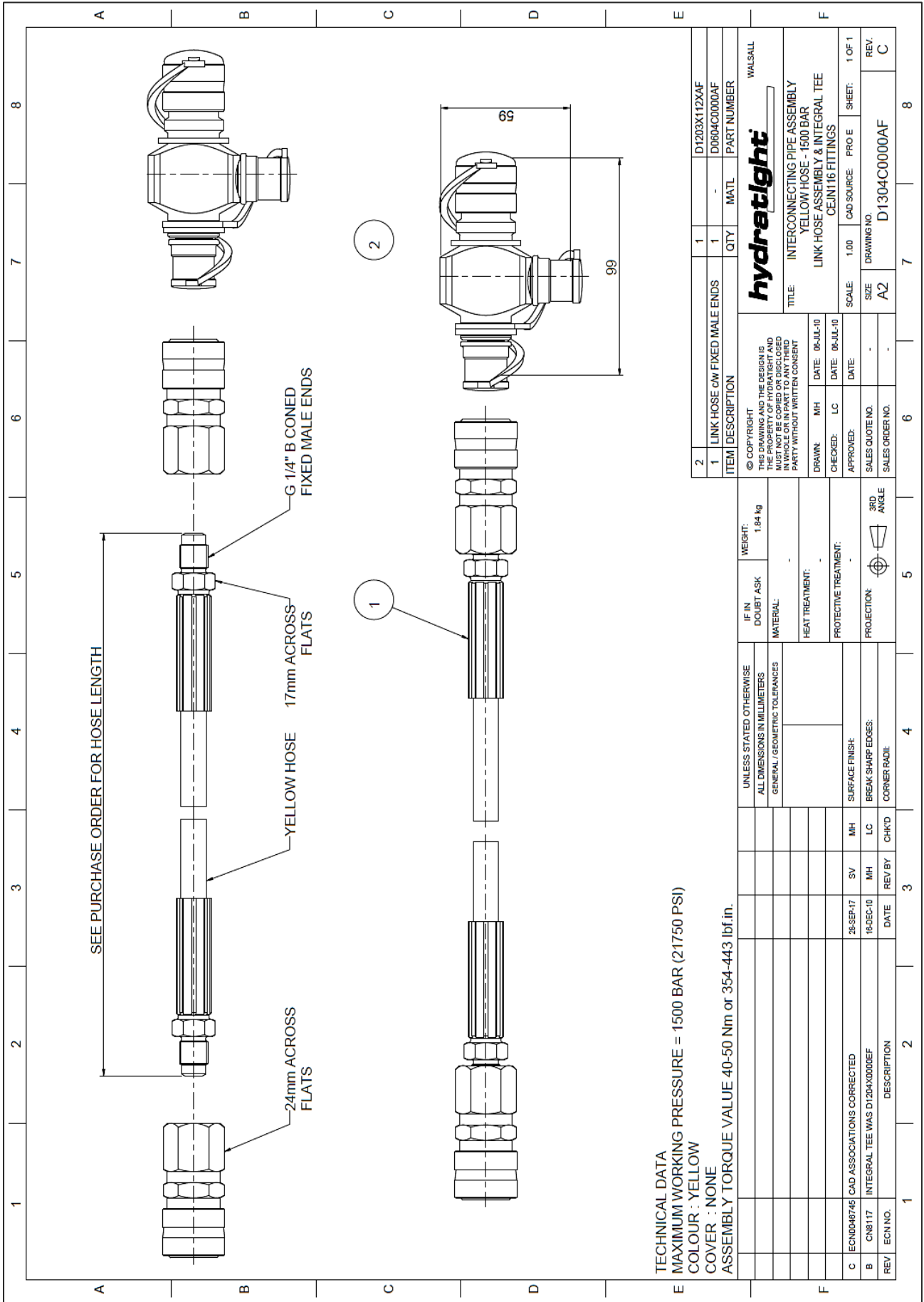

TECHNICAL DATA
 MAXIMUM WORKING PRESSURE = 1500 BAR (21750 PSI)
 COLOUR : YELLOW
 COVER : NONE
 ASSEMBLY TORQUE VALUE 40-50 Nm or 354-443 lbf.in.

2	LINK HOSE CW FIXED MALE ENDS	1		D1203X112XAF
1	LINK HOSE CW FIXED MALE ENDS	1		D0604C0000AF

ITEM	DESCRIPTION	QTY	MATL	PART NUMBER
© COPYRIGHT THIS DRAWING AND THE DESIGN IS THE PROPERTY OF HYDRATIGHT AND MUST NOT BE COPIED OR DISCLOSED TO ANY OTHER PARTY WITHOUT WRITTEN CONSENT				
DRAWN:	MH	DATE:	06-JUL-10	
CHECKED:	LC	DATE:	06-JUL-10	
APPROVED:		DATE:		
SALES QUOTE NO.				
SALES ORDER NO.				

UNLESS STATED OTHERWISE ALL DIMENSIONS IN MILLIMETERS GENERAL / GEOMETRIC TOLERANCES	IF IN DOUBT ASK	WEIGHT: 1.84 kg
	MATERIAL:	
	HEAT TREATMENT:	
	PROTECTIVE TREATMENT:	
	SURFACE FINISH	
	BREAK SHARP EDGES:	
	CORNER RADI:	
	PROJECTION:	3RD ANGLE

ECN0046746	CAD ASSOCIATIONS CORRECTED	SV	MH
CH8117	INTEGRAL TEE WAS D1204X0000EF	MH	LC
REV / ECH NO.	DESCRIPTION	DATE	REV BY
			CH'D

TITLE: INTERCONNECTING PIPE ASSEMBLY YELLOW HOSE - 1500 BAR LINK HOSE ASSEMBLY & INTEGRAL TEE CEJN116 FITTINGS			
SCALE:	1.00	CAD SOURCE:	PRO E
SIZE:	A2	DRAWING NO.:	D1304C0000AF
SHEET:	1 OF 1	REV.:	C

© COPYRIGHT THIS DRAWING AND THE DESIGN IS THE PROPERTY OF HYDRATIGHT AND MUST NOT BE COPIED OR DISCLOSED TO ANY OTHER PARTY WITHOUT WRITTEN CONSENT				
hydratight				
WALSALL				

ANNEX 1. ENVIRONMENTAL STATEMENT

Hydratight Limited operates an environmental management system and is certified by LRQA to BS EN ISO 14001:2004 under certificate identity number 10004864.

A principle objective of such a system is to minimise, where technically possible and economically viable, the impacts of a company's activities on the environment. This is particularly relevant to the recycling and safe disposal of packaging, oils and metallic component parts at the end of their useful life. As part of Hydratight's commitment to good environmental practice we respectfully urge our customers to consider such matters in their use of Hydratight bolt tensioning equipment.

Hydraulic bolt tensioning equipment is typically 98% alloy steel by weight and can be readily recycled. Hydraulic fluid remnants within the tensioners should be carefully drained and disposed of in line with local environmental directives. The remaining non-metallic seals are not readily recycled. Further advice on recycling and safe disposal methods can be obtained from local environmental agencies.